

Product Overview

Kawasaki Precision Machinery

Power Precision Control

Hydraulic pumps, motors and valves



Welcome

Around the globe, the name **Kawasaki** is synonymous with **quality** and **innovation**.

With over 100 years of experience and expertise, Kawasaki Precision Machinery has developed complete hydraulic systems fit for the needs of 21st century applications. Kawasaki's hydraulic pumps motors and accessories are designed to fit across a huge range of applications in the marine, agricultural and construction industries. We not only draw on cutting edge research from our own R&D facilities but also from across the Kawasaki Global network. Combining world class R&D with global manufacturing means we continue to push the boundaries of efficiency and controllability leaving our customers with the best possible results.

Power Precision Control

Wherever lifting, pumping, moving, steering, or controlling is required, Kawasaki's advanced solutions lead the way. Every day, our solutions enhance efficiency, reduce energy waste, and optimize performance to keep industries moving forward.

04 Mobile and Off-Highway



05 Industrial



06 Marine



07 Agriculture



09 Axial Piston Pumps



17 Axial Piston Motors



20 Staffa Radial Piston Motors



26 Control Valves



32 Future Hydraulics



36 Hydrogen



38 Sales and After Service Network



Mobile and Off-Highway

Powering Performance in the Toughest Environments

Kawasaki hydraulic systems drive the world's toughest off-highway and mobile machinery—delivering power, precision, and control where it matters most. From construction and earthmoving to road building, and material handling, our high-performance components keep heavy-duty machines running at peak efficiency. With a relentless focus on R&D, we maximize output while boosting uptime, enhancing fuel efficiency, and ensuring every drop of energy counts. Built for extreme conditions, rigorously tested for reliability—Kawasaki hydraulics keep you moving, no matter how tough the job.



Industrial

Engineering Excellence for Industrial Machinery

Since 1962, Kawasaki has been at the forefront of industrial hydraulics, delivering precision, power, and reliability to the most demanding sectors. Modern industrial machines require durability and seamless control—anywhere, anytime. Our advanced hydraulic technology enhances efficiency, reduces noise, and maximizes uptime, keeping 24/7 operations running smoothly.

Innovating for Maximum Efficiency

With cutting-edge engineering, our latest hydraulic pumps set new benchmarks in energy efficiency—delivering more power with less waste, making them the smartest choice on the market.

Quality built in.

We design our hydraulics to adapt to a variety of working fluids, with improved tolerance to contamination.

Marine

Power You Can Rely On

In the harshest marine environments, reliability is everything. Kawasaki hydraulic components are built to withstand extreme weather and rough seas, delivering unwavering performance 24/7. Our industry-leading Staffa radial piston motors set the standard for efficiency and durability. Their hydrostatically balanced design minimizes wear, maximizes torque, and ensures smooth, powerful operation—even under the toughest conditions.

Whatever the challenge, trust Kawasaki to keep you moving.



Agriculture

Precision Control for Smarter, Sustainable Agriculture

As demand grows and challenges mount, control and efficiency in agriculture and forestry have never been more critical. Kawasaki delivers cutting-edge hydraulic solutions that maximize performance while minimizing environmental impact. By combining cross-sector expertise, advanced research, and breakthrough innovation, our engineers have developed a range of high-performance components designed for the toughest agricultural applications. Proven for reliability and best-in-class efficiency, Kawasaki technology keeps machines running longer, working smarter, and delivering more with less.

Kawasaki's complete range

Engineered for quality, efficiency, and innovation, Kawasaki components are redefining performance in construction machinery.

While each product delivers exceptional results on its own, combining them into a complete system unlocks maximum machine efficiency with:

- /// Precision control for superior handling
- /// Optimized efficiency to reduce energy waste
- /// Lightweight, compact design for better integration
- /// Low-noise operation for improved working conditions
- /// Unmatched reliability for long-lasting performance



AXIAL PISTON PUMPS

Kawasaki is a world-leader in pump efficiency and performance. Within our range you'll find some of the most efficient axial piston pumps available on the market today. And because our engineers understand our customers' needs, each pump has been designed to deliver high performance across a diverse range of applications.

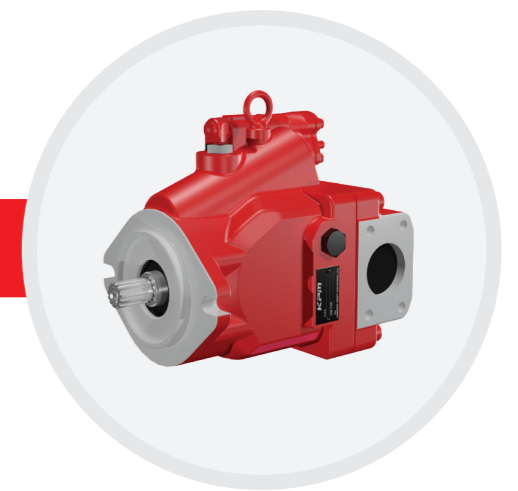

K3VLS

Variable displacement swash plate type axial piston pump.

Applications:

Main pump for mini excavators, backhoe loaders and more in the construction industry.

Key Features

- /// High overall efficiency
- /// High power density
- /// Stable and responsive controls
- /// Low noise

Model		K3VLS50	K3VLS65	K3VLS85	K3VLS105	K3VLS150
Displacement (cc/rev)		50	65	85	105	150
Pressure (bar)	Rated	280				
	Peak	350				
Speed (rpm)	Max for self priming	3,250	3,000	3,000	2,640	2,400
	Max	2,700	2,600	2,500	2,300	2,200

K3VL

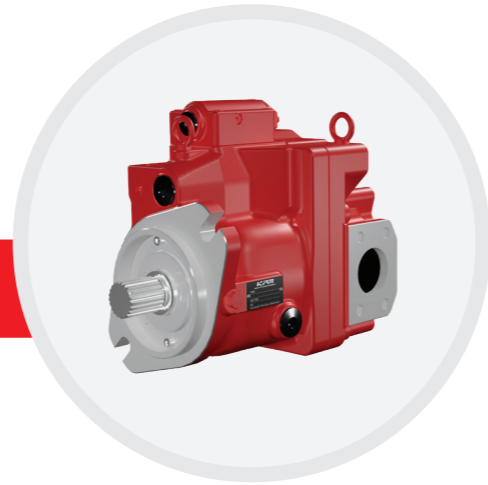

Variable displacement swash plate type axial piston pump.

Applications

Designed to satisfy the marine, mobile and industrial markets where a medium/high pressure variable displacement pump is required.

Key Features

- // Modular design - each product can be tailored to a project requirement.
- // Low pulsation and noise emissions. <80 Db(A)
- // High level of pump control with hydrostatically balanced swash plate and large bore tilting piston

Model		K3VL28	K3VL45	K3VL80	K3VL112	K3VL140	K3VL200	K3VL200H
Displacement (cc/rev)		28	45	80	112	140	200	200
Pressure (bar)	Rated	320			350			
	Peak	350			390			
Speed (rpm)	Max. for self priming	3,000	2,700	2,400	2,200	2,200	1,900	2,200
	Max.	3,600	3,250	3,000	2,700	2,500	2,200	2,200

K3V/K5V

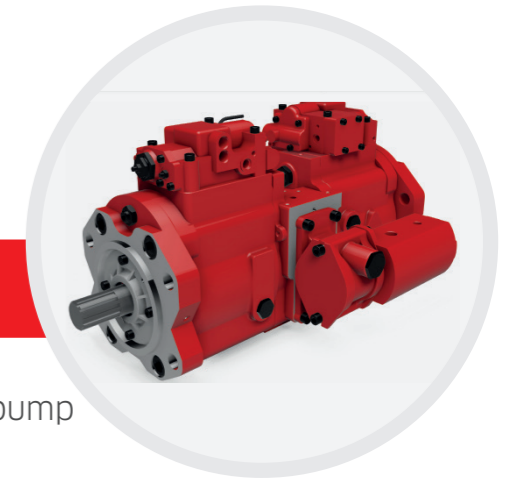

Variable displacement axial piston swash plate pump for excavators with single, tandem and parallel versions available.

Applications

Excavator, wheel loader, rough terrain crane, crushers.

Key Features

- // High efficiency
- // Wide range of power, pressure and displacement controls available
- // One common suction port for Kawasaki's DT pumps

Model		K3V63	K3V112	K3V140	K3V280	K5V80	K5V140	K5V160	K5V200
Displacement (cc/rev)		63	112	140	280	80	140	160	200
Pressure (bar)	Rated	343							
	Peak	392							
Speed (rpm)	Max. for self priming	2,650	2,360	2,150	1,600 (2,000)*	2,460	2,160	2,000 (2,350)*	1,900 (2,200)*
	Max.	3,250	2,700	2,500	2,000	3,000	2,500	2,350	2,200

*max speed with centrifugal pump

Handling displacement

The K5V pump range easily handles increased of displacement, despite having the same installation dimensions and regulator variations as the K3V.



K7V

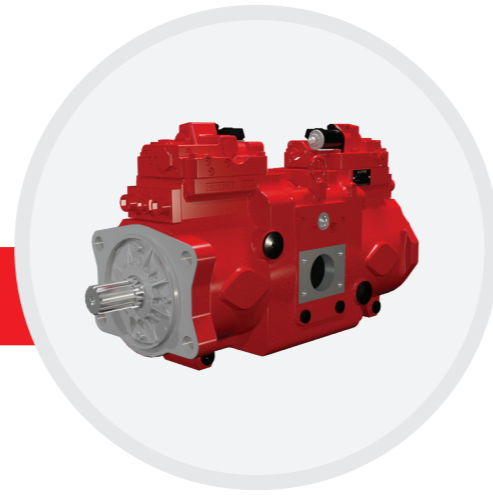

Swash plate type axial piston pump.

Applications

Main pump for excavators, drill rigs, crushers.

Key Features

- ✓ Adopting KHI advanced technology
- ✓ Increase bearing capacity
- ✓ Increase self-priming capability
- ✓ Higher input torque

Model		K7V63	K7V125	K7V140	K7V160	K7V180	K7V240	K7V280
Displacement (cc/rev)		63	130	140	160	180	242	280
Pressure (bar)	Rated	350						370
	Peak	400						420
Speed (min ⁻¹)	Max. for self priming	2,650	2,360	2,200	2,100	2,000	1,850	1,800
	Max.	2,950	2,700	2,500	2,350	2,300	2,100	2,000

Long Life

In developing the K7V, Kawasaki's engineers adopted high-load bearings and our friction free hydrostatically balanced piston shoes. The result: an impressively high level of reliability and a much longer life.

K3VG

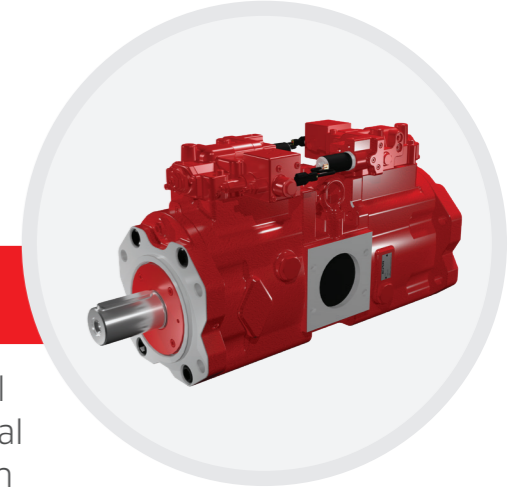

The K3VG series are variable displacement axial piston pumps of swash plate design for industrial equipment. Available as single & tandem units in larger frame sizes.

Applications

Plastic machinery & die casting, press machines, metal plants, waste treatment, hpu's, cargo vessels, oil tankers.

Key Features

- ✓ High efficiency
- ✓ Compatible with fire-resistant fluid
- ✓ Wide range of power, pressure & displacement control available
- ✓ One common suction port for DT pumps.

Model		K3VG63	K3VG112	K3VG180	K3VG280	K3VG180DT	K3VG280DT	
Displacement (cc/rev)		63	112	180	280	360	560	
Pressure (bar)	Rated	343						
	Peak	392						
Speed (rpm)	Max. for self priming	2,600	2,200	1,850	1,600	1,850	1,600	
	Max.	3,250	2,700	2,300	2,000	2,300	2,000	



K7SP

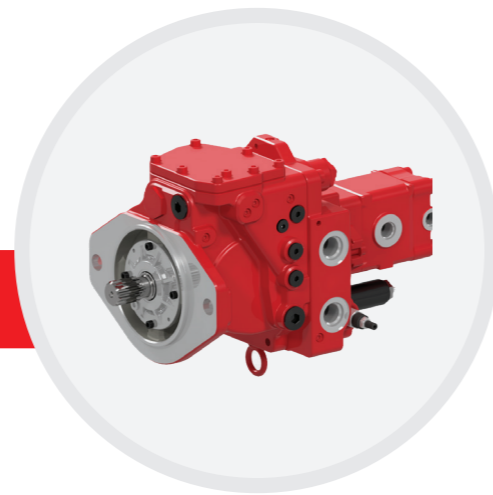

Swash plate type split flow axial piston pump.

Applications

Midi excavator.

Key Features

- /// Compact split flow type
- /// High reliability with reinforcing rotary parts
- /// Low noise valve plate
- /// Option to have common-suction type gear pump

Model		K7SP36
Displacement (cc/rev)		36×2
Pressure (bar)	Rated	300
	Peak	320
Max. for self priming		2,300

K3VLC

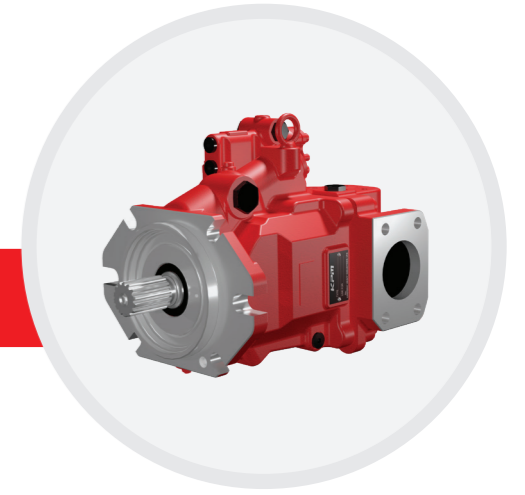

Variable displacement swash plate type axial piston pump.

Applications

Tractor and agricultural machinery.

Key Features

- /// Compact and responsive
- /// High Suction Capability
- /// Swash angle Sensor
- /// Double Shaft Seal

Model		K3VLC
Displacement (cc/rev)		85
Pressure (bar)	Rated	210
	Peak	250
Max. for self priming		2,700



K7VG

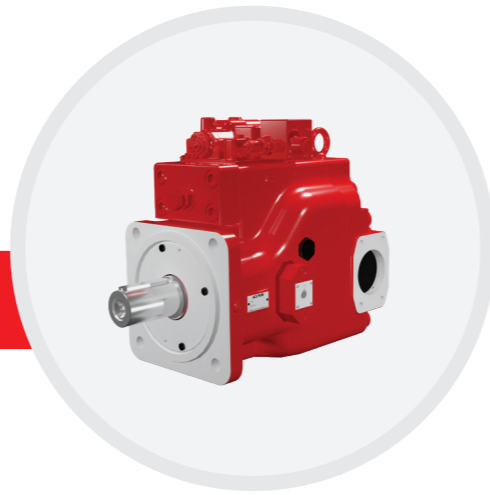

The K7VG series are variable displacement axial piston pumps of swash plate design for heavy duty industrial equipment such as steel manufacturing plant and press machinery.

Applications

Plastic machinery & die casting, press machines, metal plants, waste treatment, HPU's.

Key Features

- /// High pump efficiency.
- /// Low noise pump construction.
- /// Compatible with fire-resistant fluid.
- /// Long bearing life.
- /// Wide range of power, pressure & displacement controls available

Model		K7VG180	K7VG265
Displacement (cc/rev)		180	270
Pressure (bar)	Rated	350	
	Peak	400	
Speed (rpm)	Max. for self priming	1,800	1,600*
	Max.	2,200	1,900*

*High Speed Series

Reliability

This high pressure pump is based on our unique technologies and rich experiences. Long life are made possible by utilizing an optimized piston/slipper and high-load bearings.

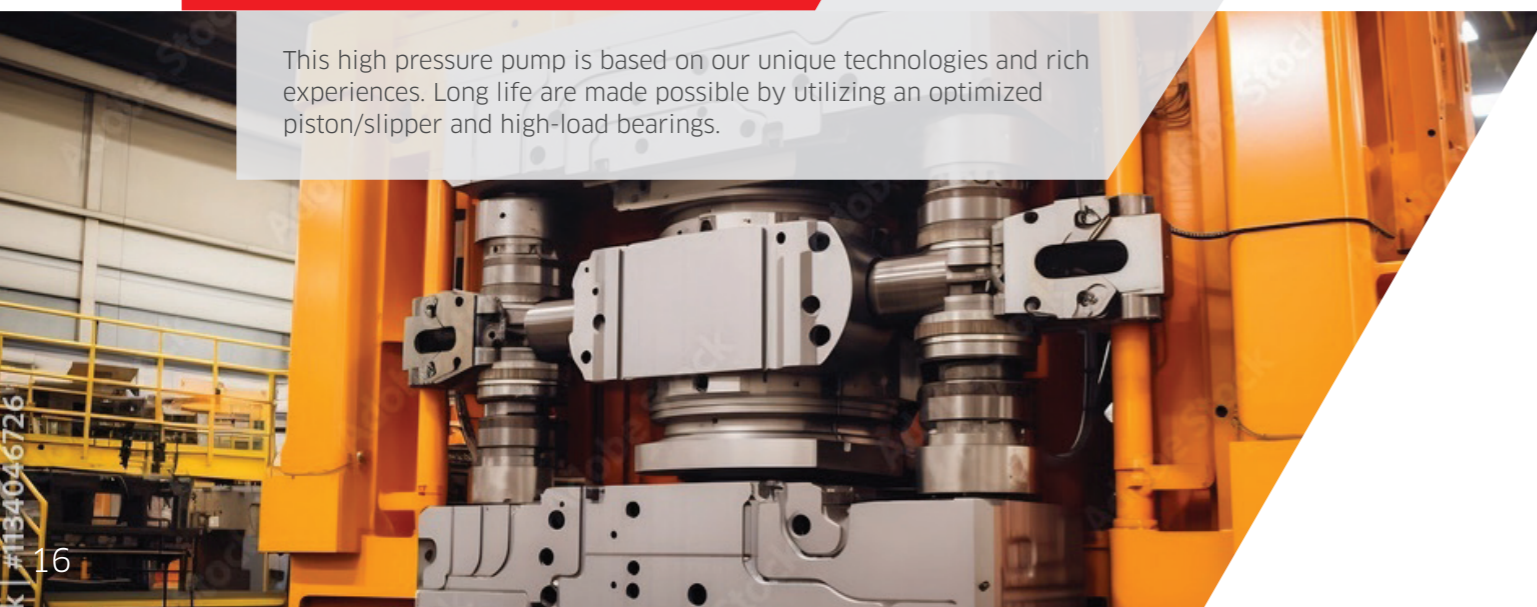

AXIAL PISTON MOTORS

Kawasaki is a world-leader in motor efficiency and performance. Within our range you'll find some of the most efficient axial piston motors available on the market today. Because our engineers understand our customers' needs, each motor has been designed to deliver high performance across a diverse range of applications.

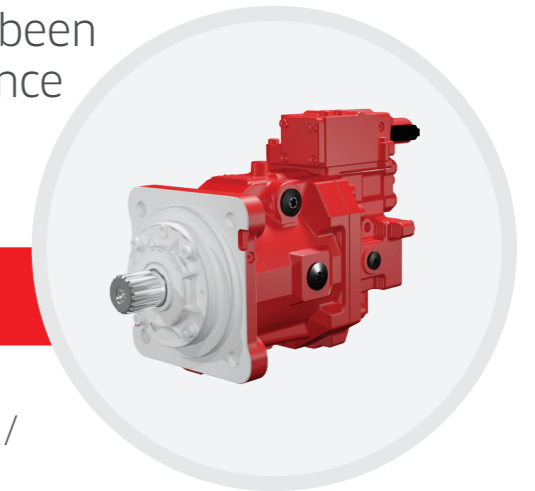

M7V

Swash plate type piston motor for high-speed operation. Hydrostatic transmission for travel / swing application.

Applications

Winch, crusher and drill rig.

Key Features

- /// Superior performance at high and low speed
- /// Stable low-speed performance
- /// Low noise performance
- /// High reliability and long bearing life

Model		M7V85	M7V112	M7V160	M7V212
Displacement (cc/rev)		85	112	160	215
Pressure (bar)	Rated	420			
	Peak	500			
Speed (rpm)	At Q Max	3,900	3,550	3,100	2,900
	<0.6 Q Max	6,150	5,600	4,900	4,600

M5X

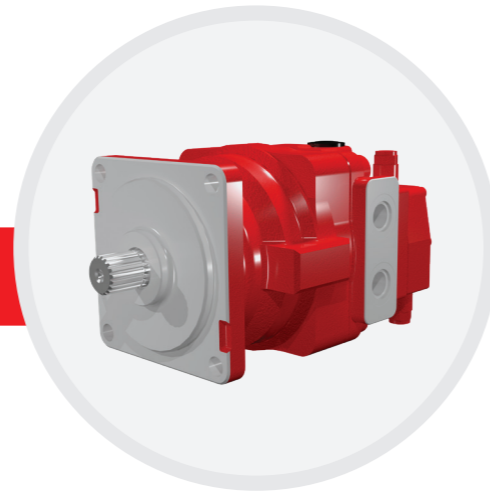

Swash plate type fixed displacement axial piston motor.

Applications

Axial piston motor for swing drive.

Key Features

- ✓ Anti-reaction valve
- ✓ Built in shockless relief valve
- ✓ Anti-cavitation
- ✓ Time-delay valve

Model		M5X50		M5X80		M5X130		M5X180		M5X250	
Displacement (cc/rev)		44	47	74	79	122	129	169	180	235	250
Pressure (Bar)	Rated	280	350	330	343	324	343	324	350	330	
	Max	330	420	400	412	392	412	392	420	400	
Max. Speed (min ⁻¹)		2,200		2,200		1,850		1,680		1,520	
Max. brake torque (Nm)		252		475		874		1,210		1,720	
Mass (kg)		24		37		47		61		100	

Developed for excellence

Improving on M2X technology, the M5X combines a best-in-class output power with a compact design.

M3X/M3B

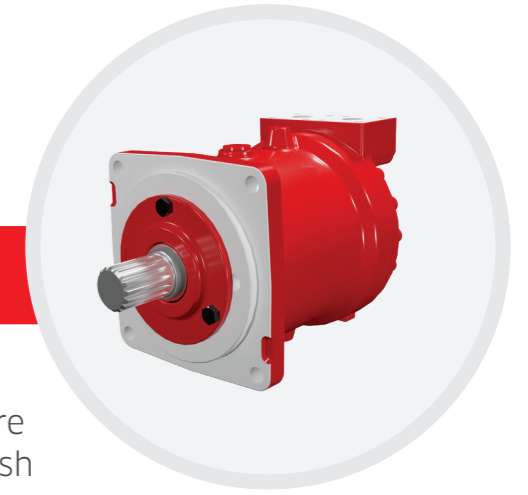

The M3X series fixed displacement axial piston motor of swash plate design & the M3B series are variable displacement axial piston motor of swash plate design.

Applications

Cranes (crawler / rough terrain), crushers, plastic machinery & die casting, cargo vessels, oil tankers, offshore vessels.

Key Features

- ✓ Superior performance in low speed operation
- ✓ Smooth starting characteristic
- ✓ Various displacement control options
- ✓ Various motor mounted control valve options

Model		M3X200	M3X280	M3X530	M3X800	M3B200	M3B280	M3B530	M3B800	
Displacement (cc/rev)		195	280	533	800	195	280	533	800	Max.
						106	93	178	267	Min.
Pressure (bar)	Rated	294				320	300	294		
	Max	343				350	350	343		
Max. Speed (rpm)		1,900	1,700	1,400	1,200	1,900	1,700	1,400	1,200	Max.
						2,930	2,200	1,700	1,500	Min.



ck | #552892470

STAFFA RADIAL PISTON MOTORS

Our Staffa motors are a range of radial piston motors, with unmatched quality, reliability, power and efficiency. Single and multiple displacement options are available.

Applications

Advanced winches, plastic injection moulding machines, deck machinery, heavy duty industrial machinery.

Key Features

- /// 5 Year warranty on all Staffa motors
- /// Market leading reliability
- /// High power density
- /// Dynamic displacement change under load
- /// High volumetric and mechanical efficiency

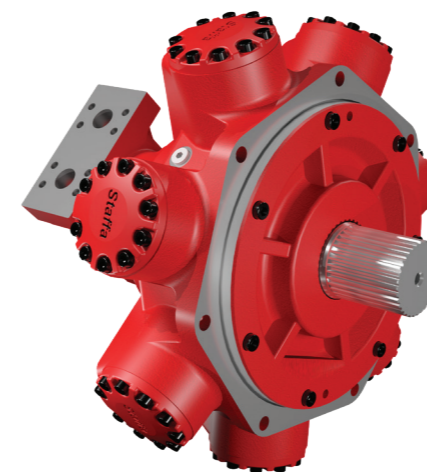

HMB Fixed Displacement

The HMB is rugged, reliable and proven design that incorporates high efficiency with good breakout torque and smooth running capability.

Model	HMB030	HMB045	HMB060	HMB080	HMB100
Displacement (cc/rev)	492	740	983	1,344	1,639
Average actual running torque (Nm/bar)	7.31	10.95	14.5	19.9	24.3
Max. continuous speed (rpm)	450	400	300		250
Max. continuous output (Kw)	52	60	80	100	110
Max. continuous pressure (bar)	207	250			
Max. intermittent pressure (bar)	250	300			

Model	HMB125	HMB150	HMB200	HMB270	HMB325	HMB400	HMB500
Displacement (cc/rev)	2,050	2,470	3,087	4,310	5,310	6,800	8,000
Average actual running torque (Nm/bar)	30.66	36.95	46.07	63.79	79.4	101	114
Max. continuous speed (rpm)	220		175	125	100	120	100
Max. continuous output (Kw)	100	115	130	140		190	170
Max. continuous pressure (bar)	250						190
Max. intermittent pressure (bar)	300						227



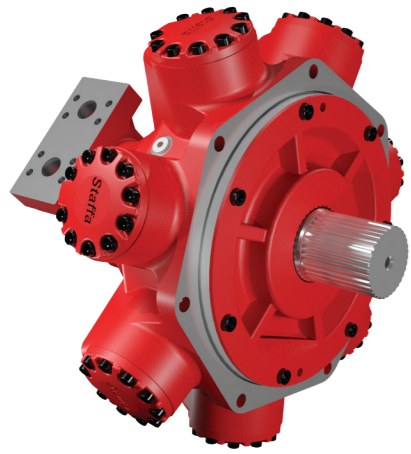

HPB Fixed Displacement High Power

Staffa HPB radial piston motors have increased speed and power ratings compared to the original Staffa HMB motor.

Model	HPB060	HPB080	HPB100	HPB125	HPB150	HPB200	HPB270	HPB325
Displacement (cc/rev)	983	1,344	1,600	2,050	2,470	3,087	4,310	5,322
Average actual running torque (Nm/bar)	15.6	21.4	25.5	32.6	39.3	49.1	68.6	84.7
Max. continuous speed (rpm)	490	430	365	300	250	230	150	130
Max. continuous output (Kw)	131	147	165	202	234	261	278	278
Max. continuous pressure (bar)	250							
Max. intermittent pressure (bar)	300							

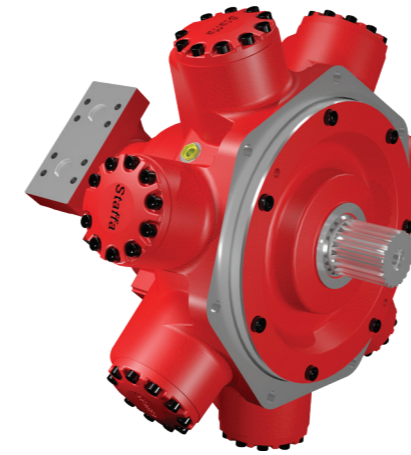

HPC Dual Displacement High Power

HPC models include special low friction components, combined with crankcase flushing flow, to achieve increased shaft power.

Model	HPC080	HPC125	HPC200	HPC270	HPC325
Displacement (cc/rev)	1,600	2,048	3,067	4,588	5,326
Average actual running torque (Nm/bar)	24.1	30.8	47.2	70.1	81.6
Max. continuous speed (rpm)	365	300	230	150	130
Max. continuous output (Kw)	165	202	261	278	278
Max. continuous pressure (bar)	250				
Max. intermittent pressure (bar)	275				



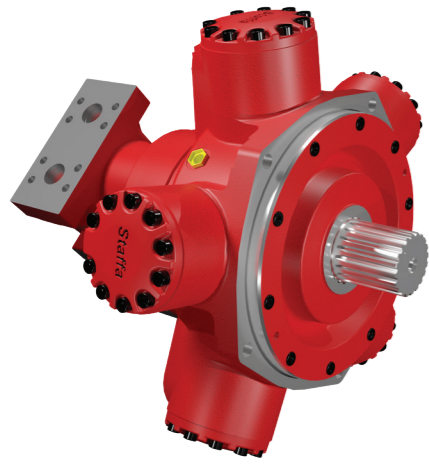

HMC Dual Displacement

The HMC has two pre-set displacements which can be chosen, from a wide range. These motors are also available in continuously variable versions using either hydro-mechanical or electro-hydraulic control methods.

Model	HMC030	HMC045	HMC080	HMC125	HMC200	HMC270	HMC325
Displacement (cc/rev)	492	737	1,600	2,048	3,087	4,588	5,326
Average actual running torque (Nm/bar)	6.86	10.63	23.9	29.9	46.6	69.4	80.4
Max. continuous speed (rpm)	450	450	365	300	230	150	130
Max. continuous output (Kw)	60	99	138	135	174	189	189
Max. continuous pressure (bar)	207	250					
Max. intermittent pressure (bar)	241	275					

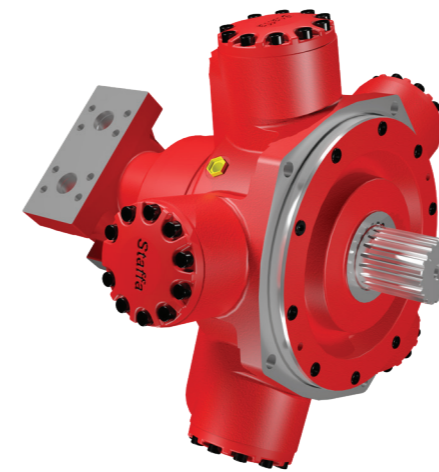

HMF Triple Displacement

The HMF was originally designed to allow 2 standard operating modes, and a 3rd 'freewheel mode' in case of emergency release - but the HMF series can equally just be used as a 3 speed motor.

Model	HMF100	HMF200	HMF270	HMF325	
Displacement (cc/rev)	1,600	3,087	4,588	5,326	
Pressure (bar)	Rated	250			
	Peak	275			
Speed (rpm)	Max	365	230	150	130

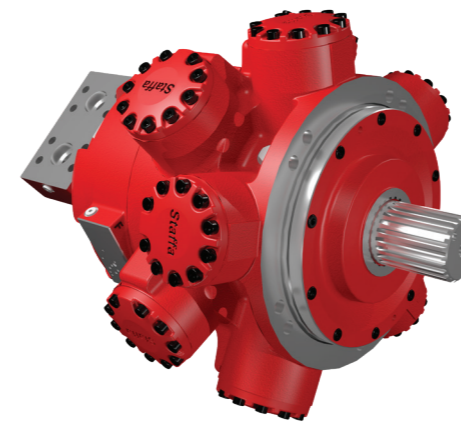

HPC400 Quad Displacement

The HPC400 has two eccentric drums which can be independently moved between high and low displacement - therefore offering customers 4 operating speeds.

Model	HPC400	
Displacement (cc/rev)	6,555	
Pressure (bar)	Rated	250
	Peak	275
Speed (rpm)	Max	220



VALVES

Kawasaki hydraulic valves and controllers provide superior performance and control for a wide variety of industrial vehicles. Every component in our range offers excellent efficiency and controllability when used alone. However, when combined with our pumps and motors, you will find they provide even greater levels of performance and reliability.

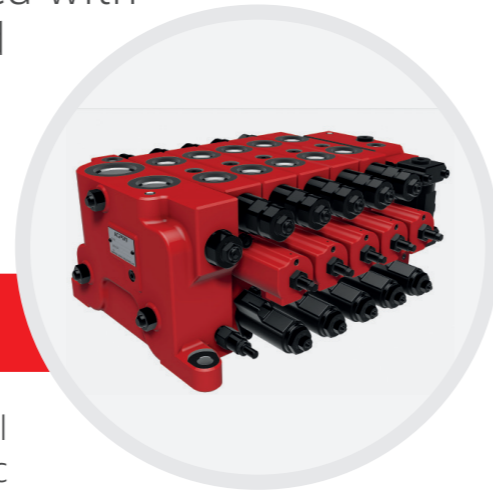

KLSV

Series of flow-sharing, load sensing main control valves with hydraulic pilot and electro-hydraulic actuation.

Applications

Crawler dozer, backhoe loader, spreaders, forestry machinery.

Key Features

- ✓ Excellent pressure-drop characteristics provide superior efficiency
- ✓ Optimal design of flow passage ensures low pressure loss
- ✓ Equipped with anti saturation function maintaining constant flow rate
- ✓ Low hysteresis allows for superior performance in pilot controller responsiveness

Model		KLSV18	KLSV22*	KLSV28*
Max. Pressure (bar)		400	350	350
Max. Flow (L/min)	P port	240	350	450
	Spool Section at $\Delta P=1.5\text{MPa}$	180	300	400

Reduced energy wastage

Thanks to the KLSV Series' optimised fluid flow path, the design of these valves significantly reduces energy wastage throughout your entire hydraulic system.

KLW/KLR

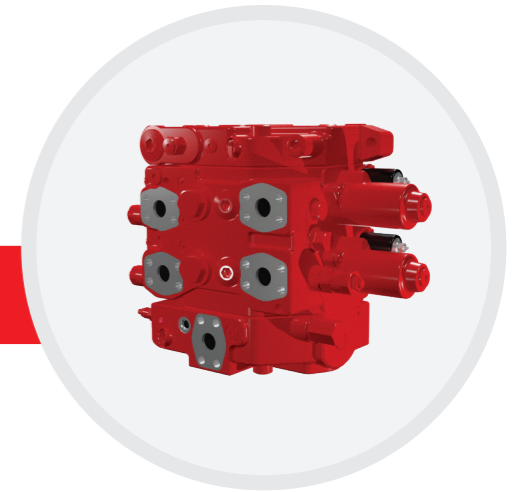

Load sensing valves for mobile machinery.

Applications

KLW - wheel loaders, KLR - skid steer loaders.

Key Features

- ✓ Implemented boom float function
- ✓ Built-in pilot shut off valve
- ✓ Equipped with two ports for boom operation
- ✓ Selectable optional features: Ride control function, energy regenerate function for buckets, increase in optional sections

Model		KLW18R	KLW22R	KLW28R
Max. Flow (L/min)	P port	220	350	450
	Section	220*	350*	400*
		*Differential Pressure = 15 Bar		
Max. Pressure (Bar)		350		
Control		Electro-hydraulic control		
		Hydraulic control		

KMX

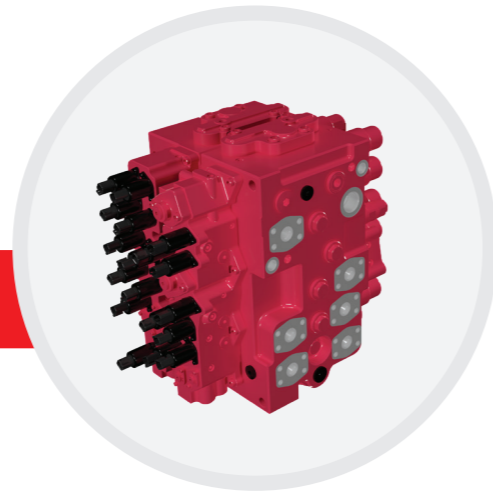

Electric multiple positive control valve.

Applications

Excavator, material handlers.

Key Features

- Option valve for breaker
- Meter-in/out independent control for arm-in
- Integrated bleed off control
- Spool position control by a proportional solenoid valve

Model	KMX13	KMX15	KMX32	KMX36
Max. Pressure (bar)	380			
Rated Pressure (bar)	350			
Rated Flow (L/min)	180	300	450	550

Built for your needs

Depending on requirements, the KMX can include sets of special-function circuits.

KDRDE5K / KWE5K



Series of electric proportional and directional pilot control valves.

Applications

Excavators, tractors, material handler.

Key Features

- Compact design
- Easy to maintain due to the cartridge type design.
- Suitable for various circuit solenoid valves with monoblock design.
- Proven performance and reliability in use with construction machinery manufacturers around the world

Model	KDRDE5K Proportional reducing valve		KWE5K Directional control valve	
Max. Pressure (Bar)	88			
Max. Flow (L/min)	10		16	
Solenoid Rating	0.7 A (DC 24 V)	1.6 A (DC 12 V)	DC 24 V	DC 12 V
Coil Resistance (Ohms)	15	3.3	41.5	10.4



PV



Series of pressure reducing pilot valves and foot pedals.

Applications

Excavator, backhoe loaders, compact track loaders, and skid steer loaders.

Key Features

- // Large range of switch options available
- // The small operational force enables minute control.
- // Excellent hysteresis.
- // The operational torque can be reduced according to the customer's requirement (patent registered)

Model	PV48K	PV48M	PVD6P	PVD8P	PV6P
Inlet Pressure (max.) (bar)	70				
Outlet Pressure (max.) (bar)	0-3				
Rated Flow (L/min)	20	15	10		

ERU



Series of high quality electrical remote-control units available in both joystick and pedal units.

Applications

Excavator, telehandler, material handler.

Key Features

- // Reduced pressure drop and quick response
- // Interchangeable/ compatible with hydraulic remote control)
- // Reduced susceptibility to external magnetic fields
- // Simple and compact designs across the series

Model	ERU2	ERUP2	ERUP1	ERUS1
Type	Joystick	Twin Pedal	Single Pedal	Single Axis Lever
Lever Angle (deg)	23.0	12.4	12.4	21.5
Operating Torque (Nm)	1.3-2.6	6.5-15.3	4.9-8.8	0.5-2.0
Output Type	Analogue/PWM/CanBus			

Developed for the environment

The Kawasaki ERU Series uses an electromagnetic noise-proof, fully waterproof construction making it highly reliable in any conditions.



Future Hydraulics

Kawasaki is constantly evolving, building on our expertise to meet the growing demands of modern applications. As industries push for greater efficiency, we pioneer advanced hydraulic solutions that enhance control and power while driving efficiency.

Designed for maximum durability and reliability, our next-generation hydraulics ensure machines run longer, smoother, and more efficiently, driving the future of performance of hydraulics.

K-Axle

High-Speed Electric Motor Pump Unit

Compact. Powerful. Efficient.

The K-Axle is designed for construction vehicles, delivering high performance in a scalable 50cc single or tandem unit at speeds of up to 5,000 rpm.

Key Benefits:

- 50% More Compact – Higher speeds boost power density, reducing size.
- High Efficiency – Advanced control technology optimizes speed and displacement for superior system performance.
- Flexible Installation – Mount horizontally or vertically to fit any design.

Experience next-level efficiency and power with the K-Axle.

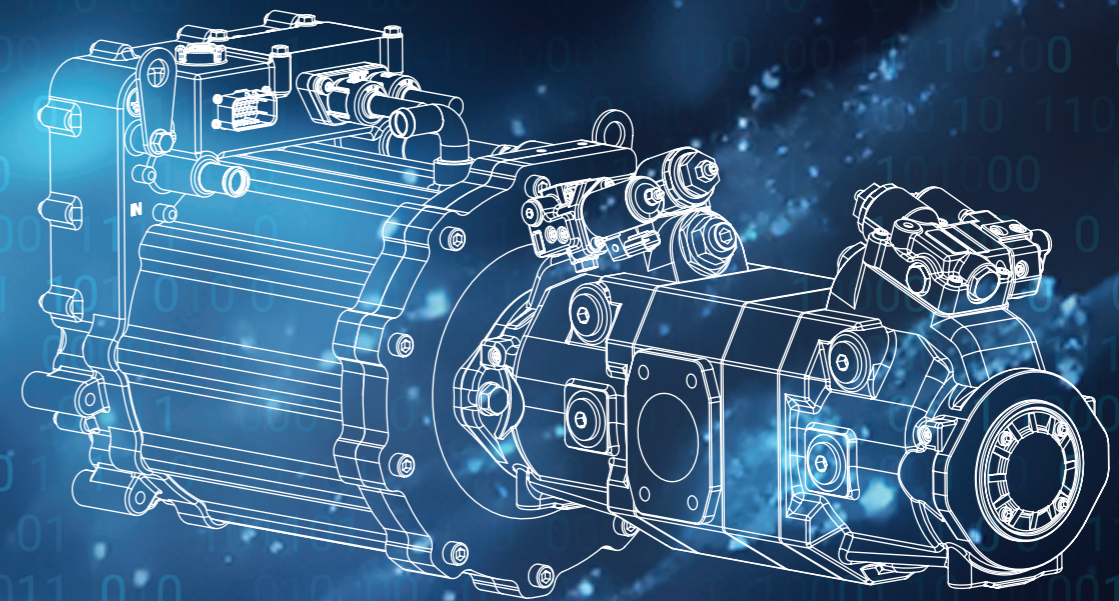

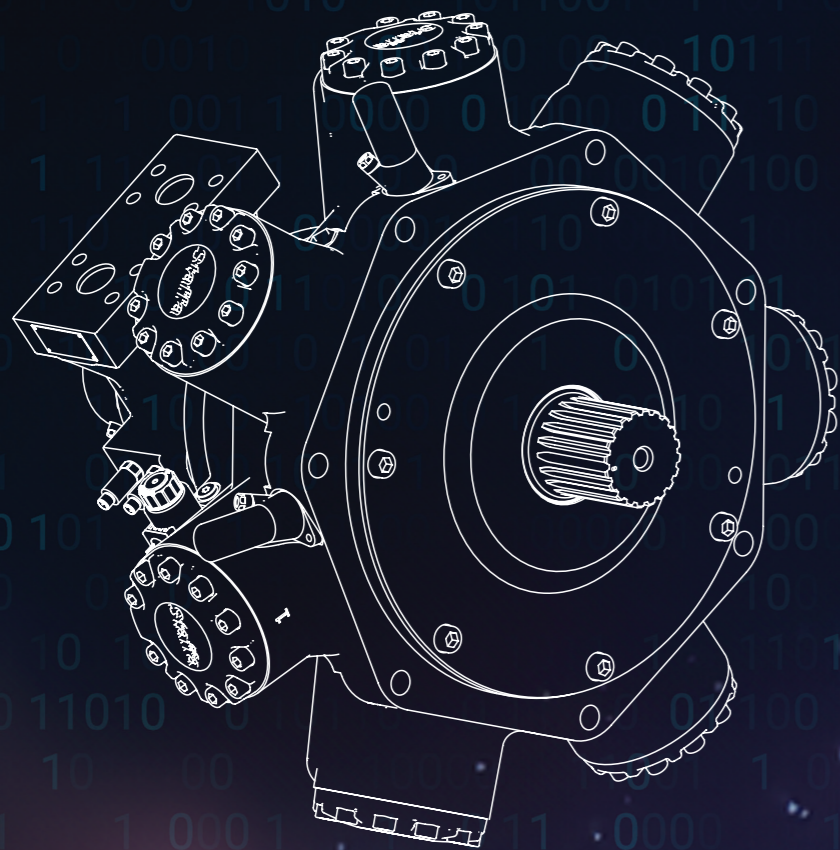

Staffa Smart Motor

Enhanced Hydraulic Precision

Hydraulic Reliability. Electronic Control.

The Staffa Smart Motor combines the proven durability of a hydraulic motor with the precision control of an electric drive.

Key Benefits:

- Closed-Loop Electronic Displacement Control – Infinite adjustability between min and max displacement.
- Continuously Variable Displacement – Hydraulic power with the seamless control of an electric drive.
- Smart Communication – Monitor and control motor speed, shaft power, and displacement in real time.

Unmatched flexibility and efficiency—Staffa Smart Motor takes hydraulic performance to the next level.

Under Development

Smart Pump

Next-Level Control for the K3VLS

Smarter. More Efficient. Fully Digital.

Introducing the digitally controlled K3VLS axial piston pump, designed for the future of mobile construction equipment. With an advanced electronic controller, it delivers unmatched precision, efficiency, and seamless integration.

Key Benefits:

- Multi-Mode Control – Supports pressure cut-off, load sense, flow, and torque control.
- Optimized Efficiency – Reduces energy loss and enhances performance.
- Seamless Integration – Connects easily with machine control systems, cutting development time.
- Customizable Settings – Set, select, and modify parameters effortlessly.
- Smart Design – Virtual minimum displacement stop and poppet-type solenoid regulator improve volumetric efficiency.

Launching first with the K3VLS85, this innovation will soon expand across the entire K3VLS and K3VL pump range.

Upgrade your hydraulic system with the power of digital control.

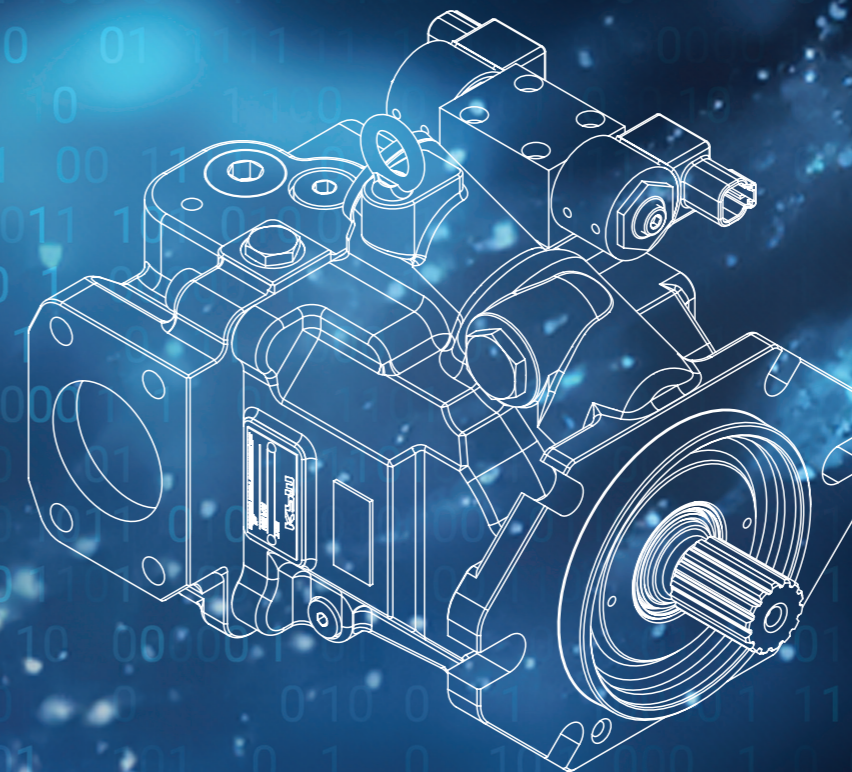

Kawasaki's Hydrogen Road: Looking to a Cleaner Future for construction vehicles

The Kawasaki Group are looking to the future and innovating better ways to power society. At the precision machinery division we are striving for excellence and making the necessity of powering the construction industry in a cleaner and more sustainable way.

Hydrogen fuel cell system and specialised associated valves.

Kawasaki is developing a fuel cell system including a hydrogen supply system to facilitate the use of fuel cells for construction machinery. This utilises Kawasaki's 70MPa class hydrogen regulator and tank valve, the KGPR120HG and KGV70H.

Proven Components for a Cleaner Solution

The Kawasaki tank valve is currently used across the automotive industry and the fuel cell supplier has extensive experience with fuel cells for commercial vehicles.

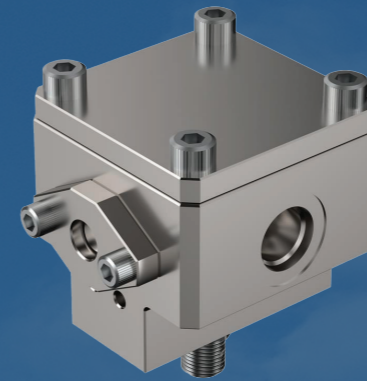

KGPR120HG

Regulator for high pressure hydrogen gas

Model	KGPR120HG
Nominal working pressure (NWP)	70MPaG
Maximum working pressure(MWP)	87.5MPaG
Outlet pressure	0.9 to 1.6MPaG (145 to 246 psi)
Flow rate	3.0g/s
Minimum inlet pressure	3.0 MPaG(450psi)
Permissible gas temperature	-40 to+85°C
Certifications	UN-R134

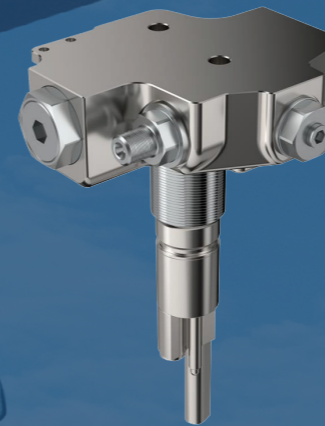

KGV70H

Tank valve for high pressure hydrogen gas

Model	KGV70H
Nominal working pressure (NWP)	70MPaG
Maximum working pressure(MWP)	87.5MPaG
CV Value	fueling 0.18 or more, defueling 0.09 or more
Permissible gas temperature	-40 to+85°C
Certifications	UN-R134

Under evaluation

Under evaluation

Global Sales & After-Sales Service Network

At Kawasaki Precision Machinery UK, we deliver world-class hydraulic solutions through a robust global sales and service network. With decades of engineering excellence, we provide superior products and dedicated support to keep your operations running at peak performance.

Worldwide Reach, Local Support

Our extensive distribution network ensures seamless access to our hydraulic solutions wherever you operate. Through authorized distributors, service centers, and sales offices, we offer local availability of high-performance pumps, motors, and control solutions, backed by expert technical support.

Comprehensive After-Sales Services

We understand that reliable after-sales support is critical to your success. That's why we offer:

- Rapid response support to minimize downtime.
- Genuine spare parts for lasting performance.
- Technical expertise for troubleshooting and guidance.
- Preventive maintenance to optimize equipment life.
- Training programs to enhance operational efficiency.

Built on Trust, Driven by Innovation

With a strong heritage in hydraulic engineering, Kawasaki Precision Machinery UK ensures you have access to industry-leading solutions and dependable support worldwide.



Kawasaki Precision Machinery:

A global partner you can trust

Kawasaki Precision Machinery(UK) Ltd

Ernesettle Lane, Plymouth PL5 2SA

United Kingdom

Email: sales@kawasakihydraulics.com



Kawasaki Precision Machinery Company

234, Matsumoto, Hasetani-cho,

Nishi-ku, Kobe, Hyogo 651-2239, Japan

Web: global.kawasaki.com

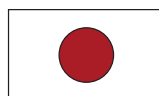

Kawasaki Precision Machinery (U.S.A.), Inc.

3838 Broadmoor Avenue S.E. Grand Rapids,

Michigan 49512

Email: contact@kpm-usa.com



Wipro Kawasaki Precision Machinery Private Limited

Kengari Hobli, No.15 & 16, Kumbalgodu Industrial Area,

Kumbalgodu, Karnataka 560074, India

Email: info@wiprokpm.com

